

BARRIERS

Traffic Barrier ◀

Guard Rails ◀

Fence With Metal Posts ◀

Fences Using the Sleeve-It™ System ◀

Barrier/Fence Rail Option ◀

Parapet Options ◀

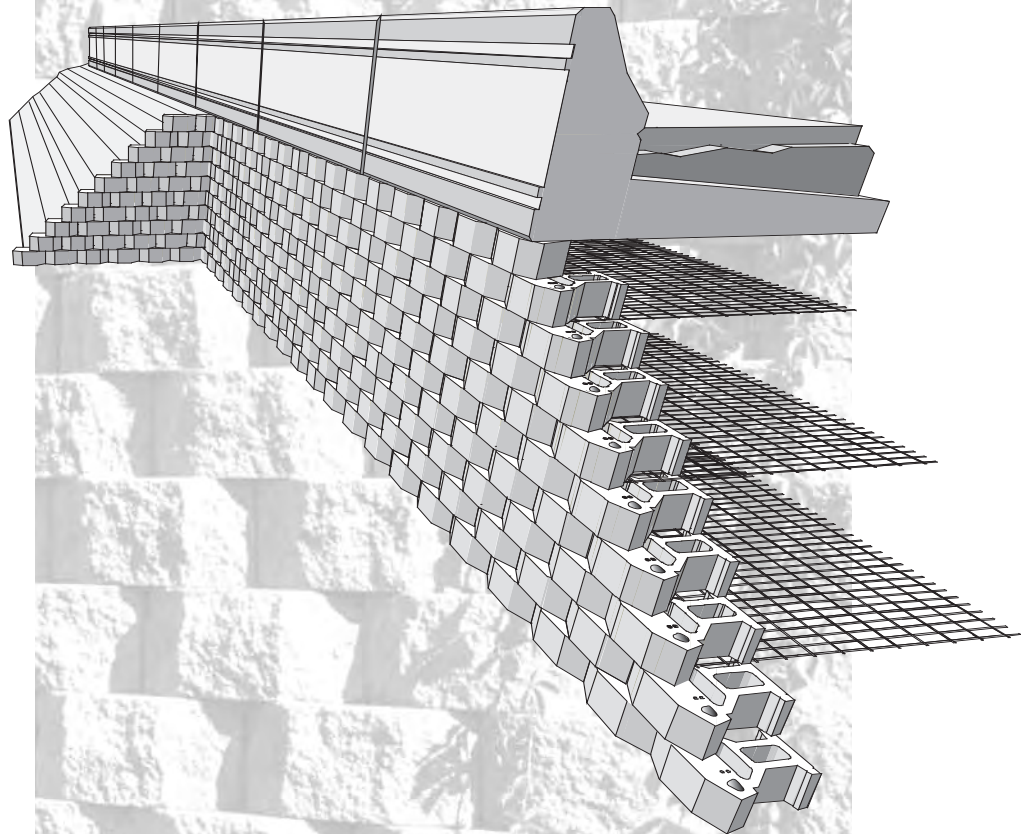

B A R R I E R S

TRAFFIC BARRIER ◀

Keystone® walls can readily be capped with a reinforced traffic barrier. Follow these procedures to install a poured concrete coping.

1. Install the Keystone® wall per general installation instructions.
2. Set and secure forming materials along the top course of the Keystone® wall using standard forming procedures. If the design requires an overhanging coping, form the edge using an “L” shaped galvanized iron or plastic forming material. Fasten this material to the top courses of the Keystone® wall. Pour and finish traffic barrier as by engineered design. Insert control joints at a maximum nine feet on center along the length of the coping, or as specified by engineer.

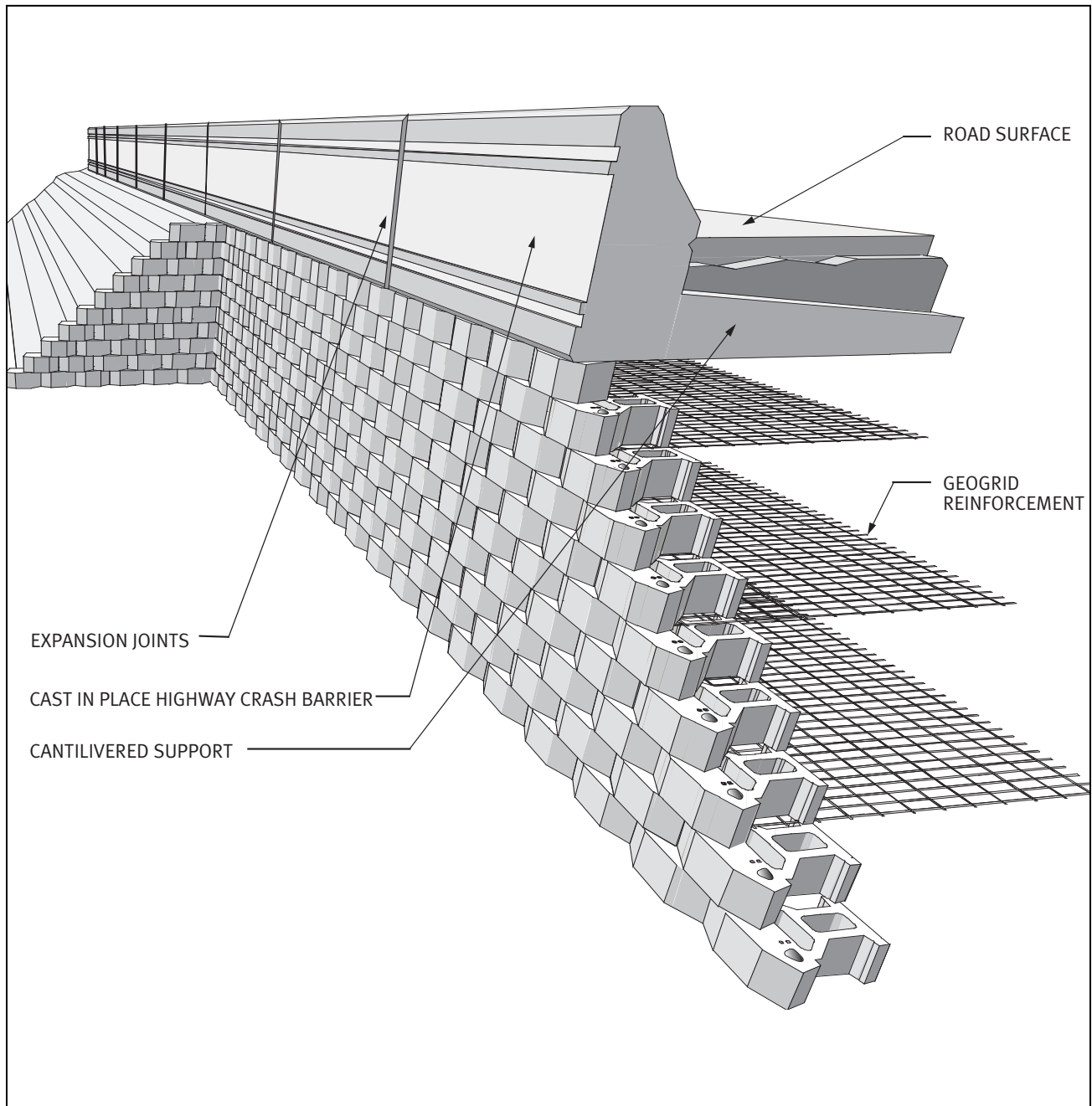

B A R R I E R S

► **GUARD RAILS**

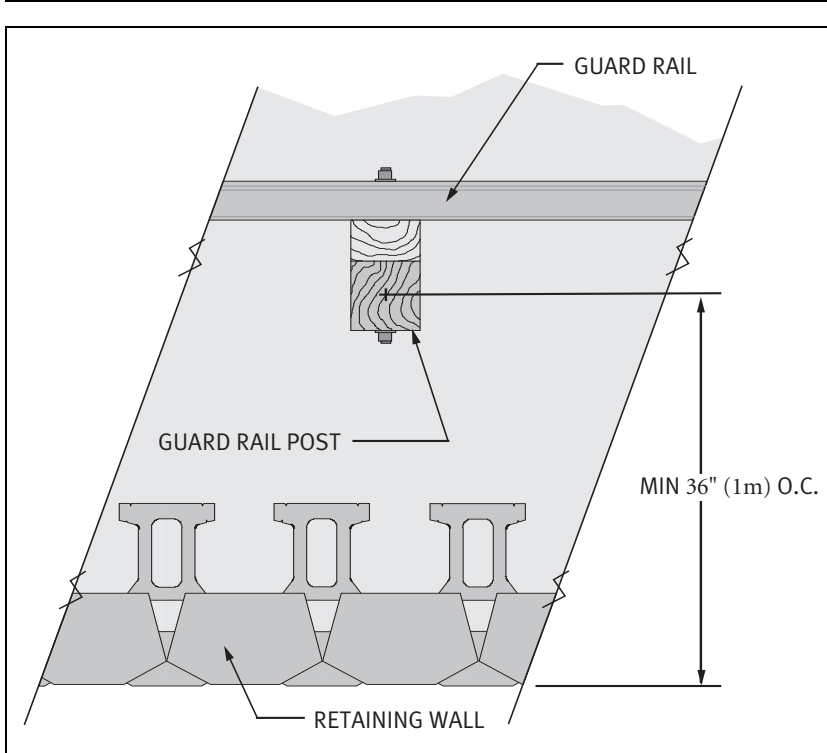
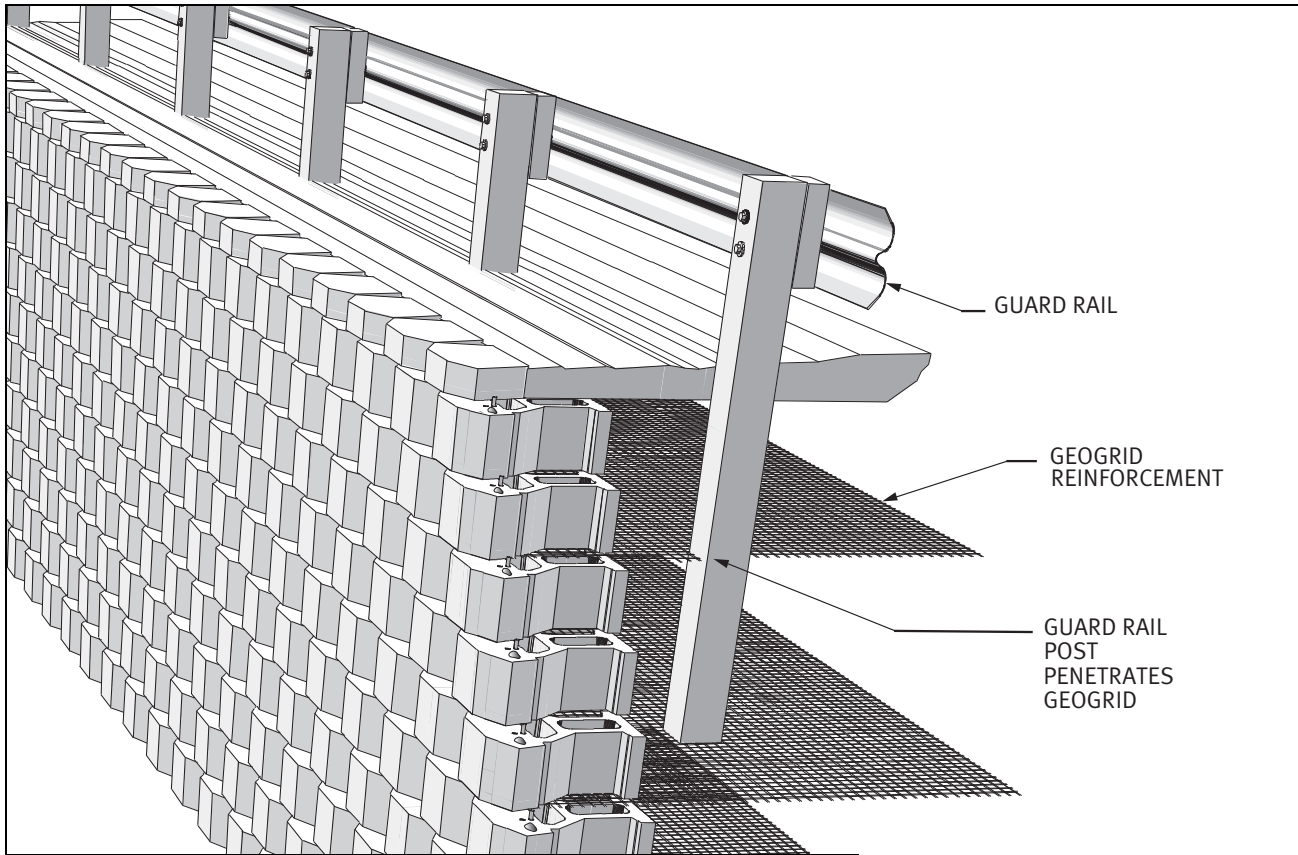

Guard rails can easily be placed along the top of a Keystone® wall using standard procedures. Posts may be of wood or steel sections. Post positions should be a minimum of 36" (0.9m) behind the wall face to provide anchoring of post into the reinforced soil area. If the wall is reinforced with geogrid, the guard rail post may be placed by cutting holes in the geogrid layers as needed per the recommendations of the geogrid manufacturer. Typically, the project engineer will provide design recommendations for this detail.

B A R R I E R S

FENCES WITH METAL POSTS ◀

Fences can be placed at the top of a Keystone® wall with fence posts placed behind the Keystone® units. Follow these procedures for proper installation of fence posts.

1. Install the Keystone® wall per general installation instructions.
2. Fence posts positioned behind the Keystone® units may be installed and anchored using standard installation methods. This position is recommended for retaining walls constructed using the Keystone® Compac Unit. Posts would be placed by normal construction methods for anchoring. If the wall is reinforced with geogrid, the guard rail post may be placed by cutting holes in the geogrid layers as needed per the recommendations of the geogrid manufacturer.

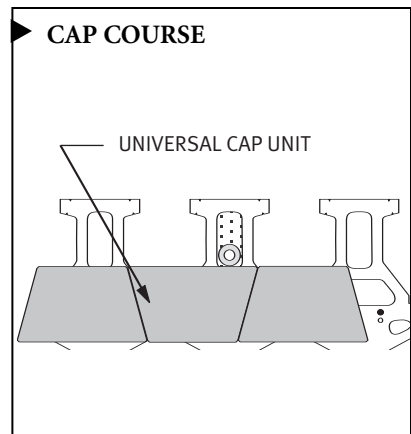
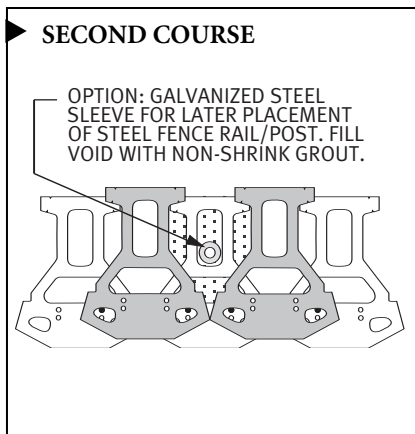
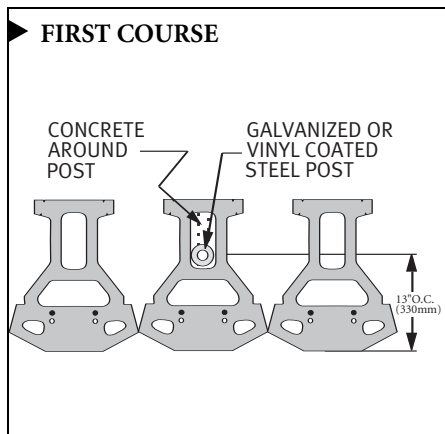
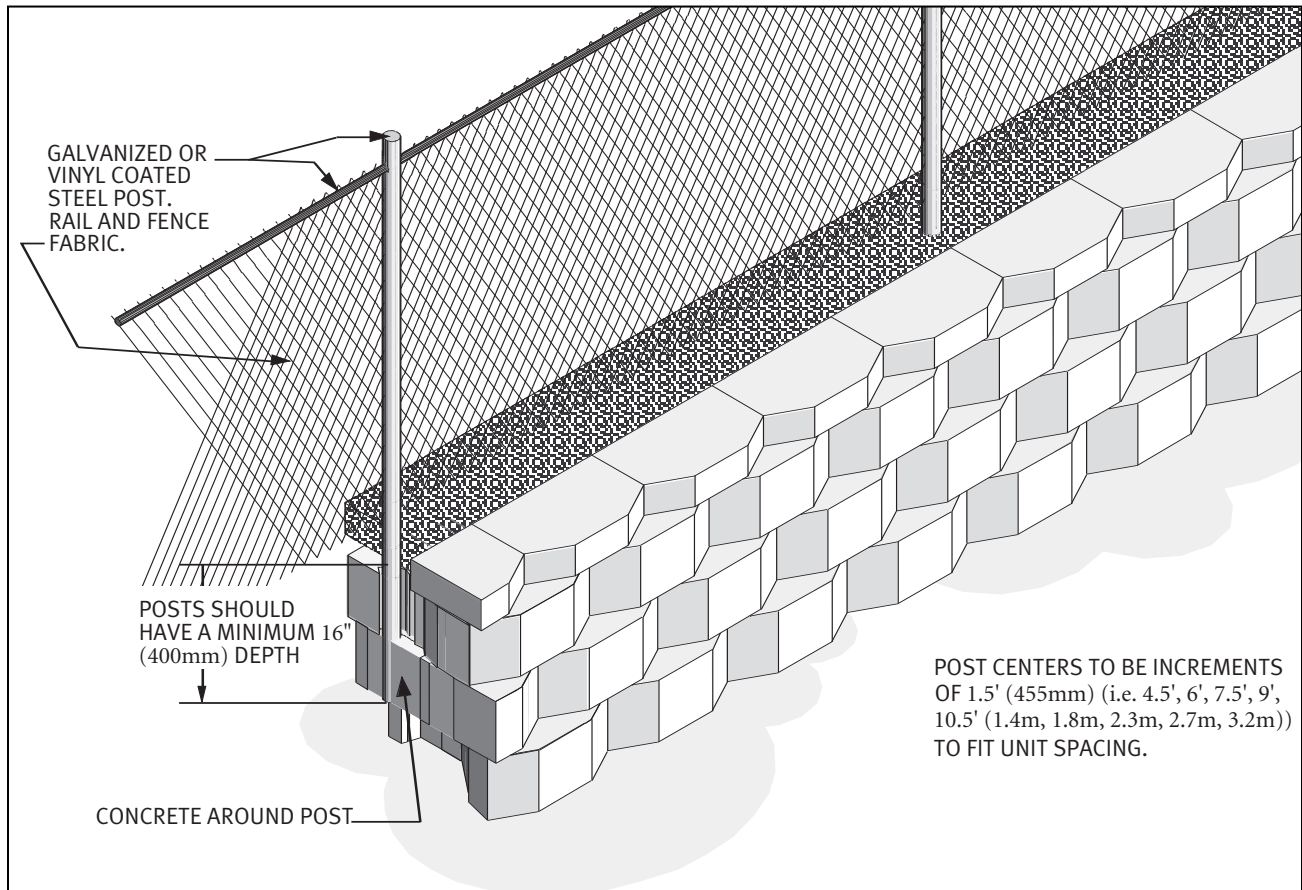

B A R R I E R S

► FENCES USING THE SLEEVE-IT™ SYSTEM

Total's building codes require fencing behind most retaining walls. With the Sleeve-It™ System, fence integration problems are easily solved.

Features and Benefits:

- Easy assembly and installation by wall installer eliminates schedule coordination with fence installer
- Universal sizes to accommodate all your fencing needs
- Engineered fence post foundation system designed to meet building code requirements
- System designed specifically to integrate with Keystone's® design and construction sequence
- Keeps fence contractor from tearing through geogrid layers and affecting integrity of wall system
- Placement of system in the 12" drainage layer allows backfill and compaction to proceed unobstructed

NOTE: Backfill and compaction within three feet of the wall face should be performed with hand operated equipment. Care should be taken during the first 6-8" lift to avoid affecting the integrity of the struts extending back into the backfill zone. Backfill and compaction must be completed to top of wall prior to installing fence post and concrete footing.

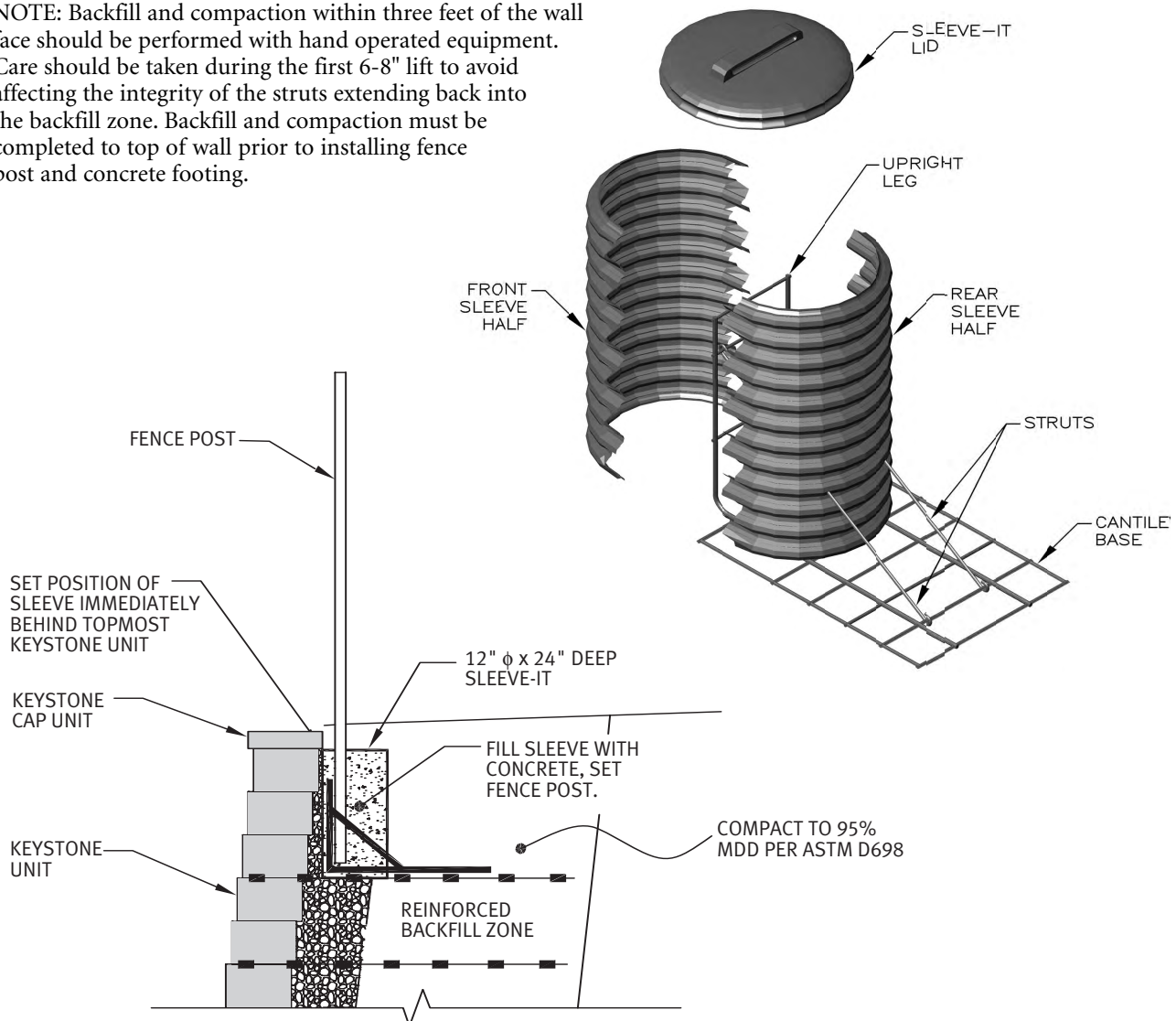

B A R R I E R S

BARRIER/FENCE RAIL OPTION

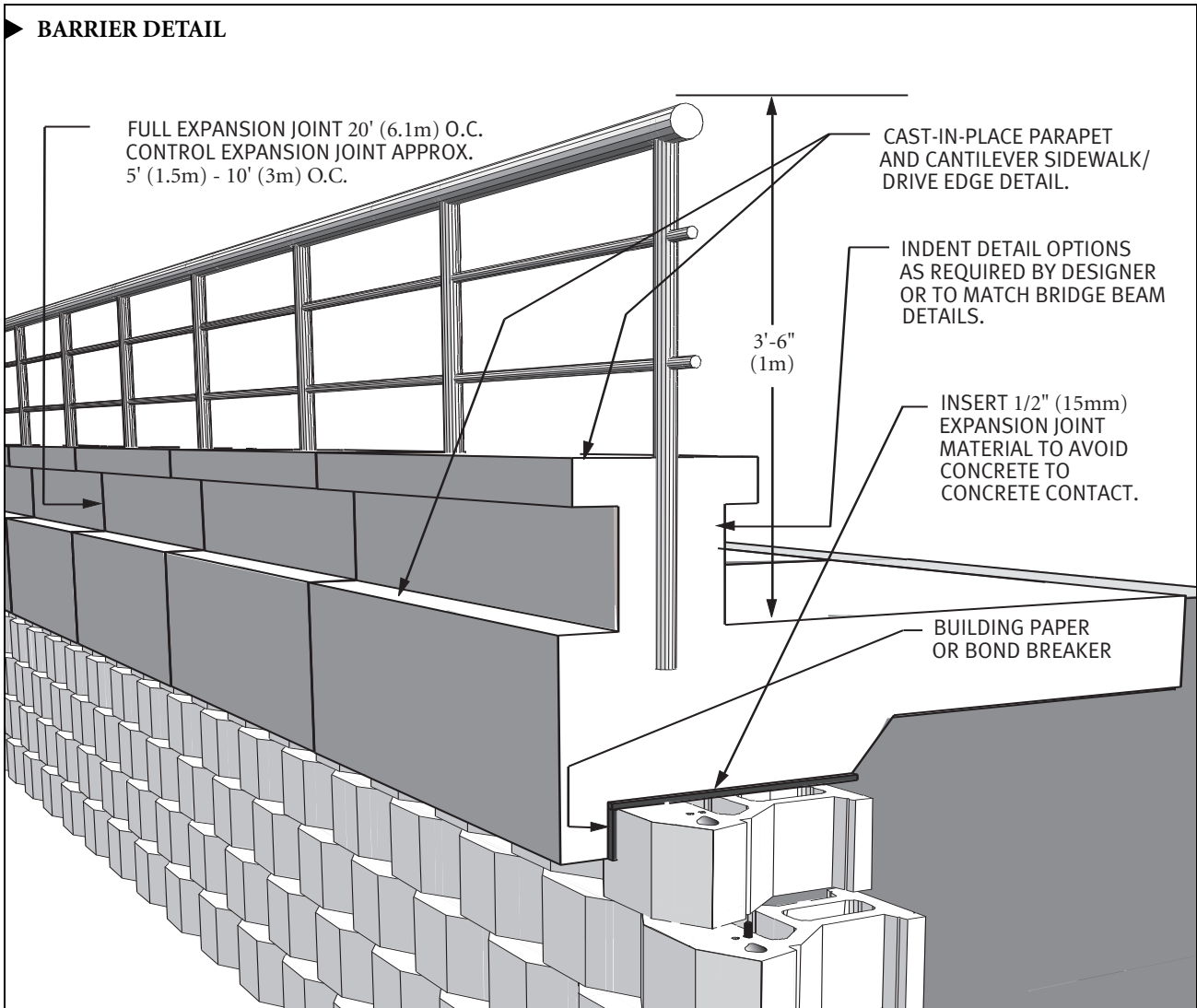

B A R R I E R S

▶ **PARAPET OPTIONS**

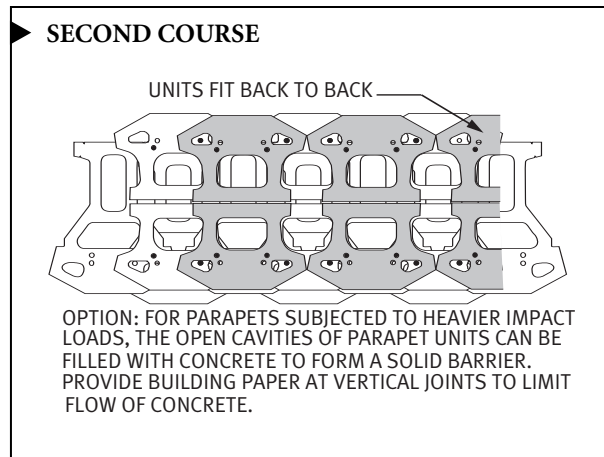
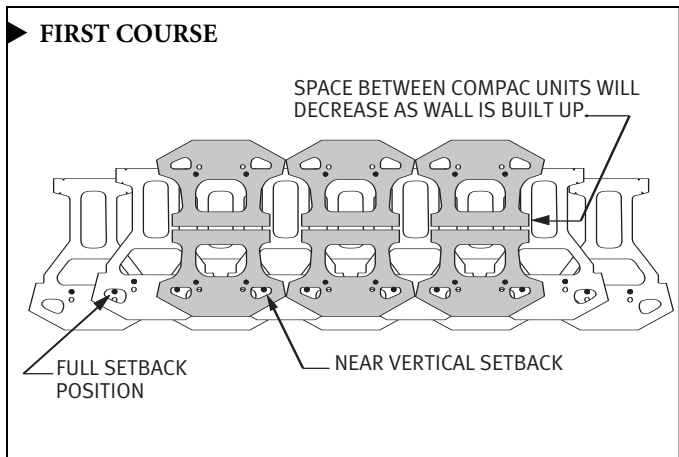
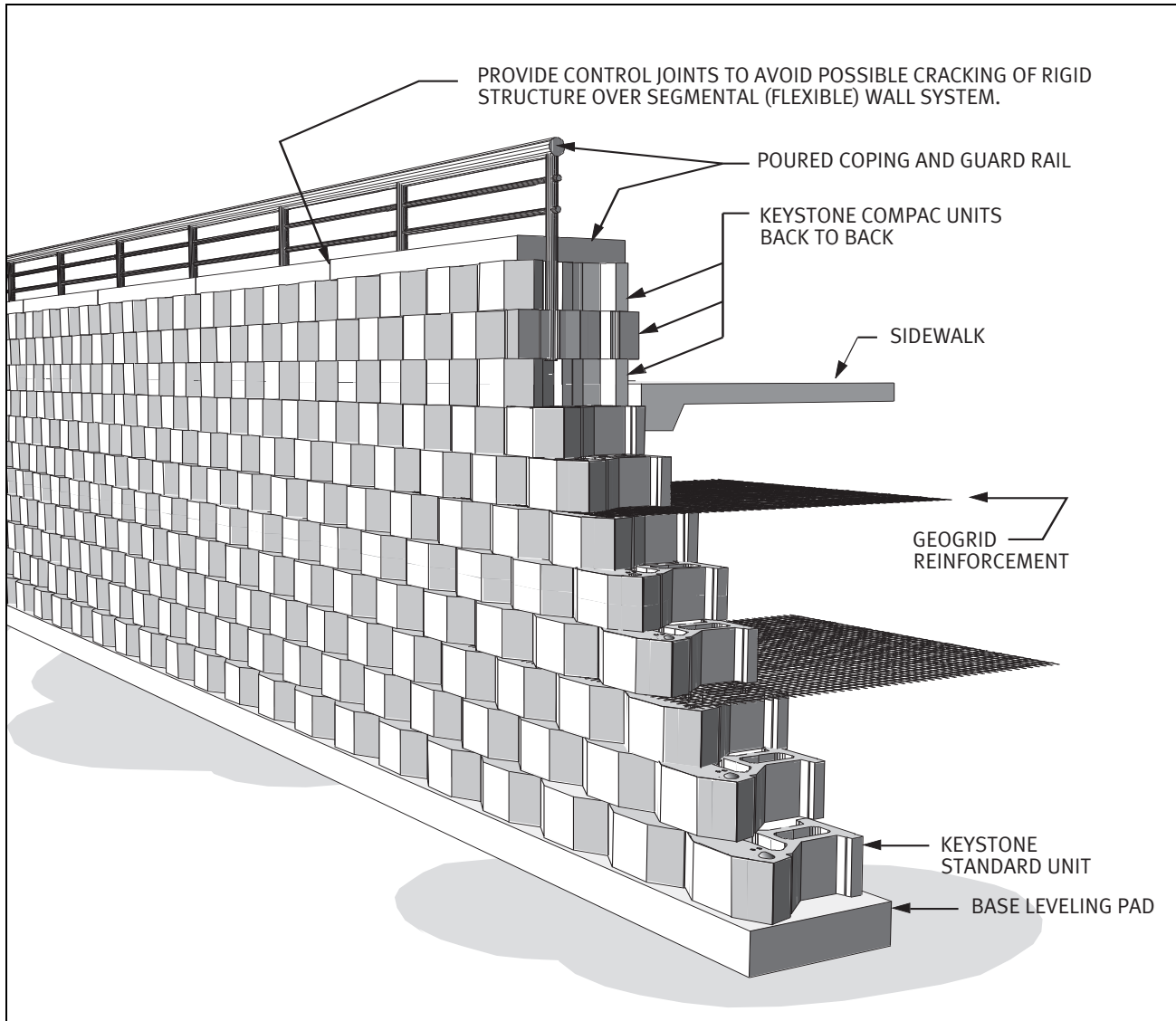

B A R R I E R S

PARAPET OPTIONS

